

Cool Concepts

For Industrial Refrigeration Systems

Issue 9— Nov., 2007

Draining Evaporative Condensers-An Alternative Approach

In this issue we will review the basic operation of specific equipment found in steam systems and compare them to the same functions found in ammonia refrigeration systems. While this may seem to be contradictory, you will find identical principles are involved.

For this comparison we will concentrate on steam coils for heating and how similar principles can be applied to draining evaporative condensers.

In both cases, a fluid (steam or refrigerant vapor) condenses when a heat sink at a lower temperature is available. In this instance, the heat sink is air at a temperature lower than the saturation temperature of the heated fluid (steam or refrigerant vapor).

As shown in Figure 1, steam flows into the unit heater. As the fans pull cool air across the finned surface of the coil, the following occurs:

- The warm steam (vapor) heats the coil sensibly
- The cool airflow causes condensation (liquid formation) of the steam

- The heat released by the condensing steam (latent heat of condensation) warms the airflow
- The warm condensate (liquid) flows out of the coil and into a steam trap

In this simple example the steam trap is shown as a float type trap. As the liquid level in the float chamber rises, the float gains buoyancy and rises. This results in the float mechanism opening, which allows the condensate to flow out of the trap and into the condensate return line.

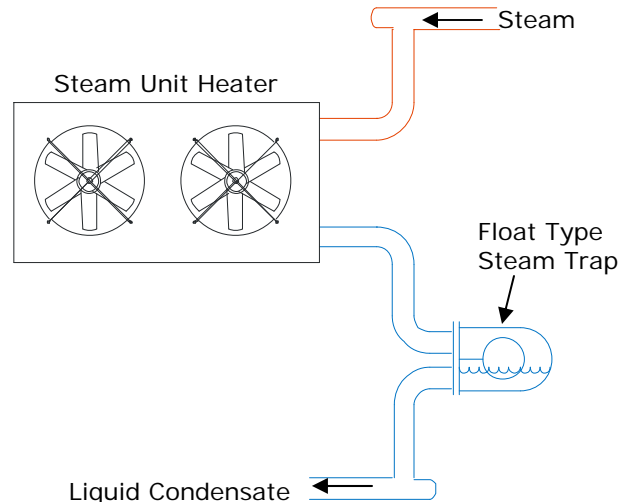

Figure 1. Example of basic steam coil heating system

Cold Systems, LLC

Contact

Phone: (608) 882-5695
Fax: (608) 882-1200
E-mail: mfisher@coldsystemsllc.com

Address

P.O. Box 202
Evansville, WI
53536
USA

Website

www.coldsystemsllc.com

In effect the float trap controls the flow direction and volume of the condensate. If the condensate flow rate decreases due to a lower heating requirement, the float trap modulates to a lower flow capacity.

Conversely if the heating requirement increases, the volume of condensate will also increase. The float trap simply passes the liquid depending on the rate of condensation.

Since the unit heater is selected to provide a specific heating capability it is easy to estimate the mass flow requirements of the steam. This mass flow rate is used to select the float trap capacity in pounds per hour (or kg/sec).

Consequently, like most flow control valves the orifice capacity is determined by the differential pressure across the orifice. As the differential pressure increases across a given orifice size, the orifice capacity increases.

On the other hand, as the differential pressure decreases the orifice capacity is also reduced.

From this simple example we see the float trap also acts as a check valve of sorts. If no condensate is available in the float chamber, the float loses buoyancy and will not allow the float mechanism to open.

This is important as this functionality will not allow gas to reverse flow back "up" through the float trap. In essence, the float trap only allows liquid to flow out of the chamber.

By comparison, an evaporative condenser operates in a similar manner as a steam heating coil. The hot high pressure ammonia flows into the condenser. The cool air and water evaporation on the external side of the condenser coil condenses the refrigerant inside the coil tubes.

As the liquid (condensate) flows out of the condenser coil, it typically flows into a high pressure receiver.

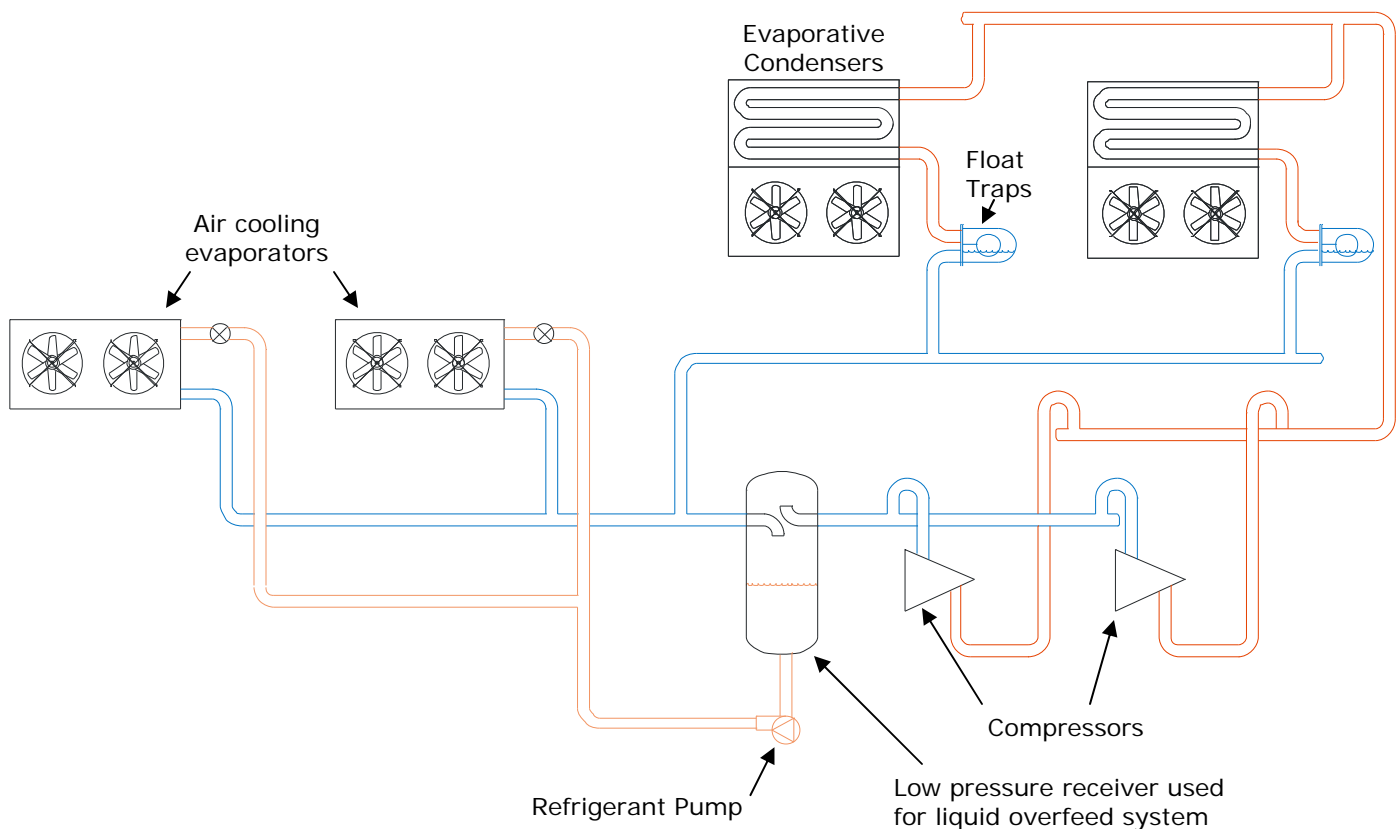

Figure 2. Example of basic single stage liquid overfeed system using high side float drainers

By configuring the refrigeration system in a different manner (Figure 2) we find the condenser coil can be provided with float drainers to operate in an identical manner as the steam coil. Figure 3 shows a cutaway of a common float trap available for industrial refrigeration purposes. These are also referred to as high side float valves or liquid drainers.

In the flow diagram shown in Fig. 2 the float traps control the liquid refrigerant flow rate from the condenser coils into a section of pipe. This pipe is at the suction pressure of the refrigeration system.

Due to this pressure differential (condensing pressure minus suction pressure) between the trap inlet and outlet, any liquid flowing out of the float traps undergoes an expansion process. This occurs in the same manner as a thermostatic expansion valve or hand expansion valve feeding high pressure liquid to a low pressure vessel.

A portion of the liquid flashes off into a vapor. The remaining liquid now exists at suction pressure at the saturation temperature of that pressure.

The cold liquid and flash gas flow into the low pressure receiver, where the liquid is separated by gravity forces and falls into the bottom of the vessel. The lighter vapor returns back to the compressors along with the gas generated in the evaporators (due to the boiling which takes place there).

KEY FEATURES

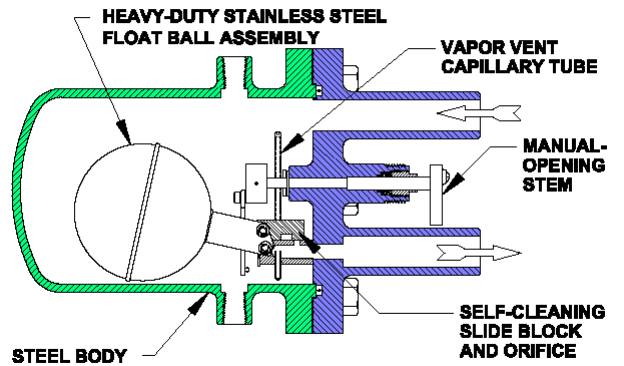

Fig. 3. Float trap cutaway courtesy of Hansen Technologies

The refrigerant pump circulates the cold liquid refrigerant out to the evaporators. As you can see this process is identical to a common liquid overfeed system (also sometimes referred to as a liquid recirculation system).

Figure 4 illustrates an important topic related to the use of the float traps. Group trapping of steam or refrigerant condenser coils is not recommended.

During various operating conditions the rate of condensing in the coils may differ. If the outlet pressure of one coil is lower than the other coil, liquid will tend to back-up into the coil with the lowest outlet pressure.

The liquid that accumulates in the coil reduces the heating capacity for a steam system. When this occurs in a refrigeration system the evaporative condenser capacity is

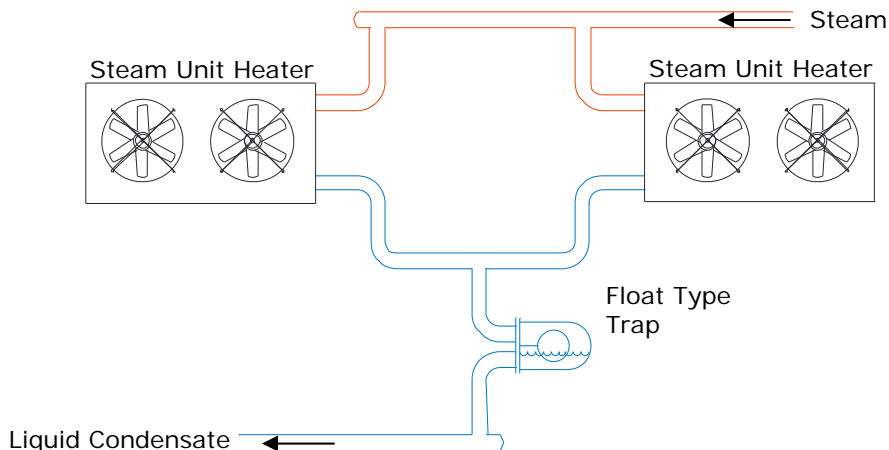

Fig. 4. Example of "group trapping". Note: Not recommended.

drastically reduced and results in an increase in the discharge pressure. To eliminate the effects of liquid accumulation in the coils it is necessary to use an individual float trap per coil as shown in Fig. 1. This applies to steam or refrigeration systems.

The logic behind this type of system configuration is that the high pressure receiver is now removed from the system. All liquid refrigerant that exists in the system is now stored at low pressure, not high pressure.

This provides a much safer installation in the event of a liquid refrigerant release as the volume of gas generated by the release will be much lower.

All oil draining activities can now be accomplished with the refrigerant at low pressure. This is inherently safer than trying to drain oil from a high pressure receiver.

By using the float traps to drain the condenser coils you also remove the equalizing line that is required when draining to a high pressure receiver. All too often the equalizing line (between the condenser & high pressure receiver) is sized incorrectly and contributes to problems associated with gravity draining evaporative condenser coils.

Another benefit of this system configuration is the potential for reducing the ammonia refrigerant charge. By careful evaluation of the evaporator coil circuiting and other areas it is possible to develop this system configuration to meet the definition of a critically charged system.

Group trapping of steam or refrigerant condenser coils is not recommended... To eliminate the effects of liquid accumulation in the coils it is necessary to use an individual float trap per coil...

In effect, this means the refrigerant charge is reduced to the lowest possible volume to meet the cooling requirements. In new system installations this methodology has provided a 50% reduction in the volume of required refrigerant .

This also has obvious impacts to the need for PSM programs by reducing the inventory of refrigerant required. Any time the refrigerant charge can be minimized will help to lower the overall exposure to offsite properties or population.

This brief discussion on an alternative condenser draining method is suggested whenever you want to achieve high performance capability of a refrigeration system.

This method allows the condensers to be operated without excess liquid being accumulated in the condenser coils. In addition this can also contribute to a reduction in the overall refrigerant charge of the system.

Also, by removing the high pressure receiver from the system the issues associated with mechanical integrity for the receiver and high pressure liquid storage are reduced.

Please contact us to see how this can provide benefits for your refrigeration system.

Cold Systems, LLC provides technical assistance to owners and other users of refrigeration systems. Our services are based on over 35 years of experience to provide you with the long-term value and benefits of:

- Energy reduction with increased efficiency & equipment capability, and
- Reduction of challenging issues & improved operational flexibility

We offer a broad range of services designed to promote safety, reliability, and cost effectiveness for refrigeration systems. Call us to discuss solutions for your system today.

